

INFISSI



# INDICE

1	AZIENDA struttura storia territorio	8	FINESTRE IN LEGNO/ALLUMINIO
2	FINESTRE IN LEGNO	9	68 L-A
3	68 BASIC	10	80 L-A
4	68 PLUS	11	SISTEMA LUCE
5	OTTANTA	12	GHOST L-A
6	NOVANTA	14	OSCURANTI
7	GHOST	15	PORTE DA INTERNI
		16	PORTE IN LAMINATO
		17	PORTE LACCATE
		19	PORTE IN MASSELLO

# STRUTTURA STORIA TERRITORIO

Tecnolegno è un'azienda nata nel 1990 dalla passione per il legno: una passione che viaggia lungo i binari della ricerca, dell'infaticabile impegno e delle più attuali tecniche di lavorazione. Progetta e realizza arredamenti su misura, infissi, porte e finestre. Nello stabilimento di oltre 3000 metri quadri si utilizzano macchinari tecnologicamente avanzati a controllo numerico. Grazie a un innovativo reparto di verniciatura, automatizzato per grandi quantità e manuale per finiture particolari, l'azienda riesce a realizzare al proprio interno tutto il ciclo produttivo garantendo un'alta qualità di finiture dei prodotti. La struttura è completata da uno show room di 500 metri quadri disposti su tre livelli dove è esposta, insieme alla produzione interna, anche una vasta selezione di marchi di alta qualità, che consentono un'offerta chiavi in mano sia per la casa che per il locale commerciale. Il bacino industriale e artigianale di primo piano che circonda Tecnolegno, completa la struttura che punta al gioco di squadra e alla concentrazione di relazioni industriali.

Infissi



i nostri marchi:

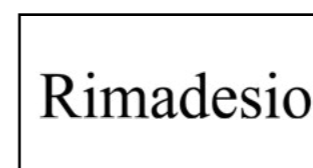

Tecnolegno

## FINESTRE IN LEGNO

68 basic

68 plus

ottanta

novanta

ghost

Le finestre di Tecnolegno sono volte a soddisfare le più svariate esigenze funzionali ed estetiche del cliente. Si va da soluzioni con profili e verniciature classiche a soluzioni più moderne con profili di telaio e ante minimali, squadrate e dalle linee pulite. Tutti i modelli esprimono una **elevata qualità** frutto del miglior connubio fra l'artigianalità dei mastri falegnami e le più moderne tecnologie utilizzate nella loro produzione e in tutti i componenti della finestra. In particolare per la ferramenta si utilizza **AGB**, da decenni sinonimo di alta qualità e di durabilità. Viene lavorato quasi esclusivamente il **legno lamellare** selezionando la migliore materia prima presente in ogni momento sul mercato. Per la verniciatura vengono utilizzate **vernici all'acqua** per l'intero ciclo, che prevede una mano di impregnante ad immersione, una mano di intermedio e una mano di finitura. Per i vetri si utilizzano **vetri camera termici ed acustici con gas argon di serie**. Sulla traversa inferiore del telaio viene montato un **gocciolatoio in alluminio**. Sono previsti **coprifili interni della sezione di mm 55x10**. Tutte le finestre sono **certificate CE** per permeabilità all'aria, tenuta all'acqua e resistenza al vento. È possibile inoltre realizzare qualsiasi tipo di anta o telaio per la ristrutturazione di **edifici storici**.

Infissi



Tecnolegno

LEGNO

2

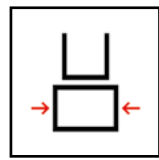

telaio:  
68 x 70 mm

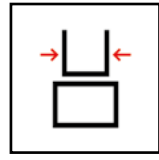

anta:  
68 x 80 mm  
68 x 70 mm

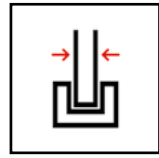

vetrocamera:  
fino a 31 mm

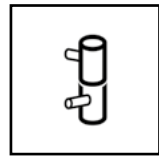

cerniere:  
AGB tipo anuba da 14 mm

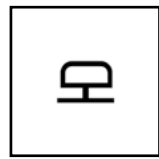

guarnizioni:  
doppia



profili:

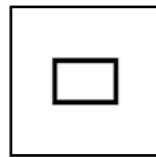

classic

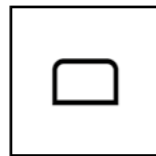

round



barocco

Infissi



Modello base della gamma, personalizzabile attraverso la scelta di tre diversi profili e due sezioni di anta, 70 o 80 mm. Con vetro 44.1 acustico - 12 gas argon - 33.1 acustico basso emissivo, l'infisso è certificato per un abbattimento acustico di 41 Db.

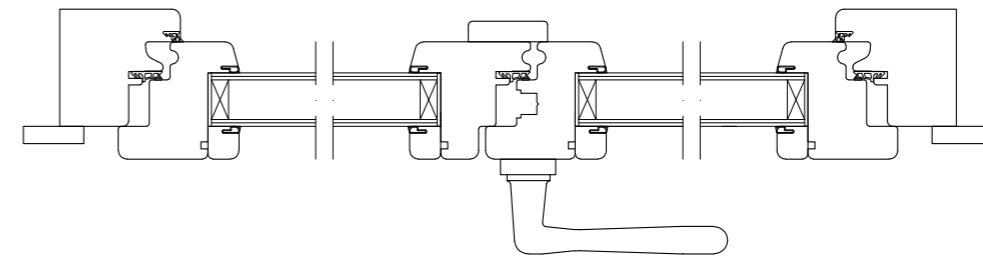

Tecnolegno

68-BASIC

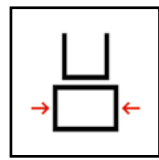

telaio:  
68 x 70 mm

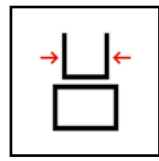

anta:  
68 x 80 mm  
68 x 70 mm

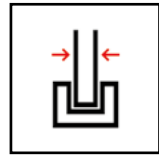

vetrocamera:  
fino a 31 mm

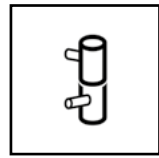

cerniere:  
AGB tipo anta a ribalta

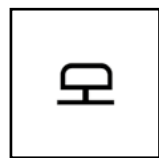

guarnizioni:  
doppia



profili:

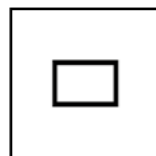

classic

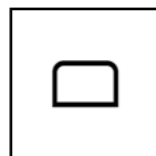

round



barocco



68-PLUS

Finestra con cerniere del tipo anta a ribalta e coprifilo complanare al telaio di serie. Nella versione con profilo classic e anta da 70 mm otteniamo una finestra più moderna dalle linee essenziali. Con vetro 44.1 acustico - 12 gas argon - 33.1 acustico basso emissivo, l'infisso è certificato per un abbattimento acustico di 41 Db.

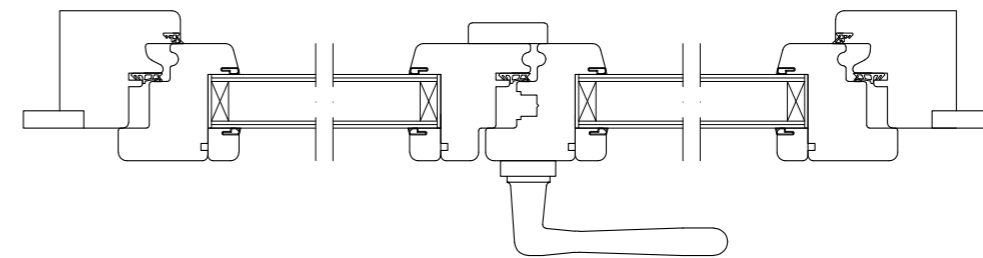

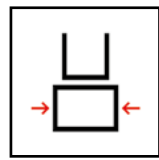

telaio:  
80 x 70 mm

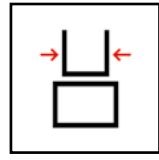

anta:  
80 x 80 mm  
80 x 70 mm

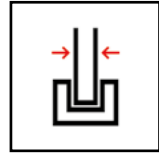

vetrocamera:  
fino a 43 mm

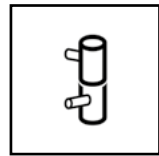

cerniere:  
AGB tipo anta a ribalta

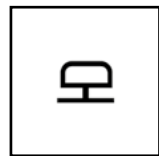

guarnizioni:  
doppia con terza guarnizione opzionale



profili:

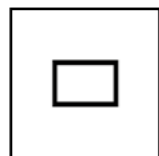

classic

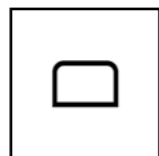

round



barocco



Finestra pensata per raggiungere migliori valori di trasmittanza termica e di abbattimento acustico. La percezione di robustezza data dalla profondità dell'infisso può essere mitigata dalla scelta di un' anta dalla sezione di 70 mm.

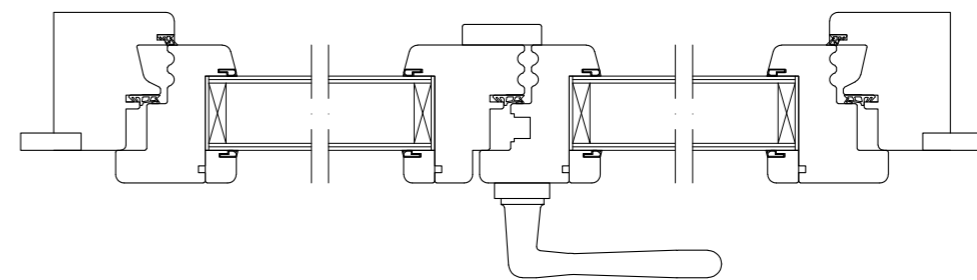

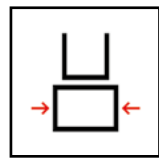

telaio:  
92 x 70 mm

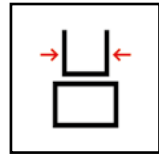

anta:  
92 x 80 mm

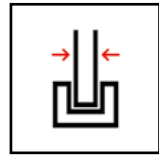

vetrocamera:  
vetro doppia camera fino a 55 mm

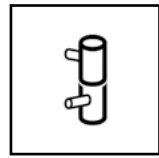

cerniere:  
AGB tipo anta a ribalta

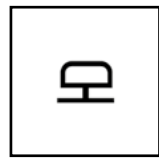

guarnizioni:  
tripla



profili:

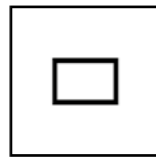

classic

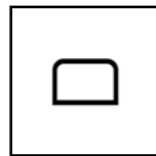

round



barocco



Modello nato per alloggiare un vetro doppia camera e per aumentare il livello di sicurezza antieffrazione grazie al suo spessore e all'utilizzo opzionale di ferramenta AGB in classe RC2 PLUS con sistema POSEIDON.

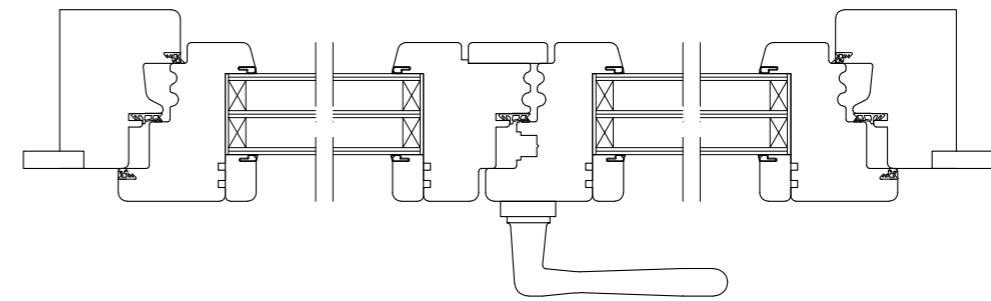

NOVANTA

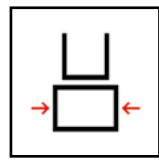

telaio:  
68 x 60 mm

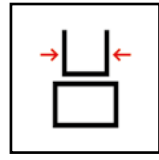

anta:  
68 x 60 mm

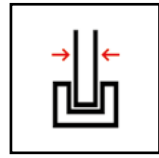

vetrocamera:  
fino a 31 mm

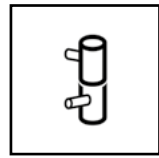

cerniere:  
AGB tipo invisibili

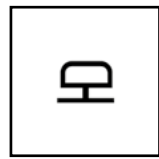

guarnizioni:  
doppia



profili:

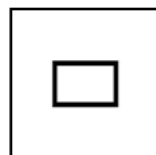

classic



Finestra moderna pensata per coloro che amano lo stile pulito e minimale. L'utilizzo di cerniere a scomparsa rende l'anta a filo del telaio, mentre il profilo da 60 mm aumenta la superficie vetrata rendendo gli ambienti più luminosi.

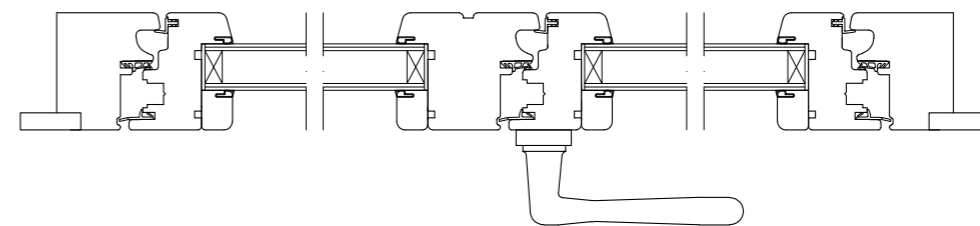

Infissi

Tecnolegno

GHOST

## FINESTRE IN LEGNO/ALLUMINIO

68 L-A

80 L-A

sistema LUCE

ghost L-A

Tecnolegno ha ideato numerose soluzioni di finestre legno-alluminio che garantiscono un eccellente connubio fra l'estetica e la naturalezza del legno nel lato interno e la resistenza e durevolezza dell'alluminio nel lato esterno. I rivestimenti esterni sono realizzati con profili di alluminio verniciato con polveri epossidiche. È possibile scegliere fra colori RAL e finiture effetto legno.

Infissi



Tecnolegno

LEGNO/ALLUMINIO

8

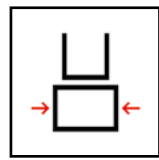

telaio:  
64 x 70 mm

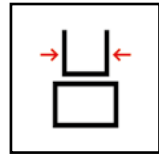

anta:  
68 x 81 mm

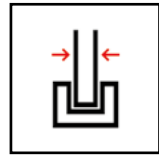

vetrocamera:  
fino a 45 mm

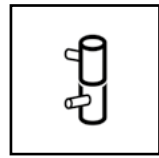

cerniere:  
AGB tipo anta a ribalta

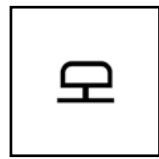

guarnizioni:  
doppia



profili:

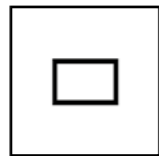

classic

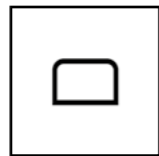

round



La classica finestra legno/alluminio concepita utilizzando le migliori tecnologie e le migliori materie prime.

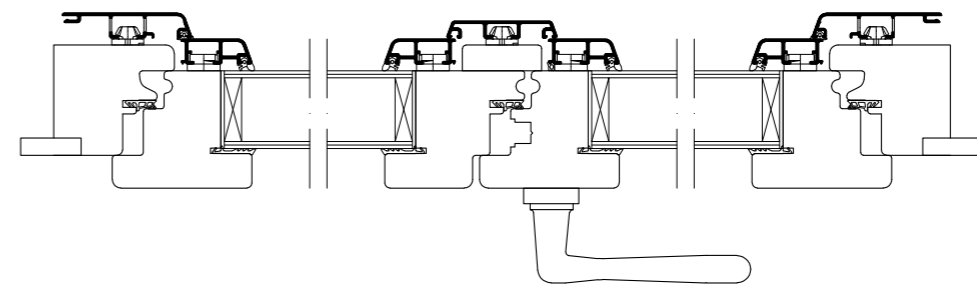

Infissi

Tecnolegno

68 L-A

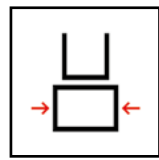

telaio:  
76 x 70 mm

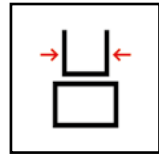

anta:  
80 x 81 mm

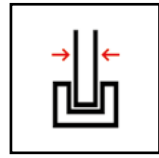

vetrocamera:  
fino a 51 mm

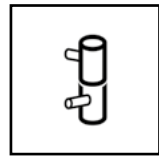

cerniere:  
AGB tipo anta a ribalta

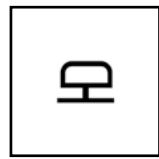

guarnizioni:  
doppia



profili:

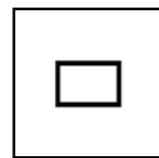

classic

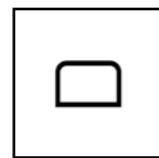

round



Finestra che combina le elevate prestazioni termiche e acustiche alla praticità dell'alluminio all'esterno.

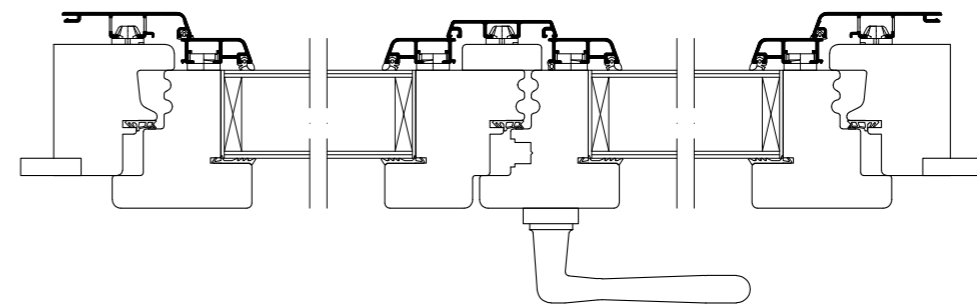

80 L-A

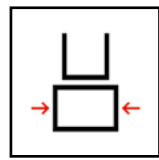

telaio:  
74 x 80 mm  
80 x 80 mm

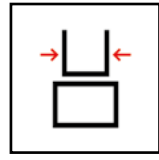

anta:  
68 x 70 mm

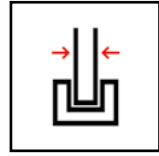

vetrocamera:  
fino a 49 mm

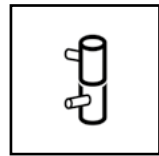

cerniere:  
AGB tipo anta a ribalta

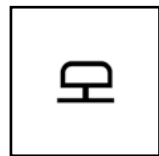

guarnizioni:  
doppia

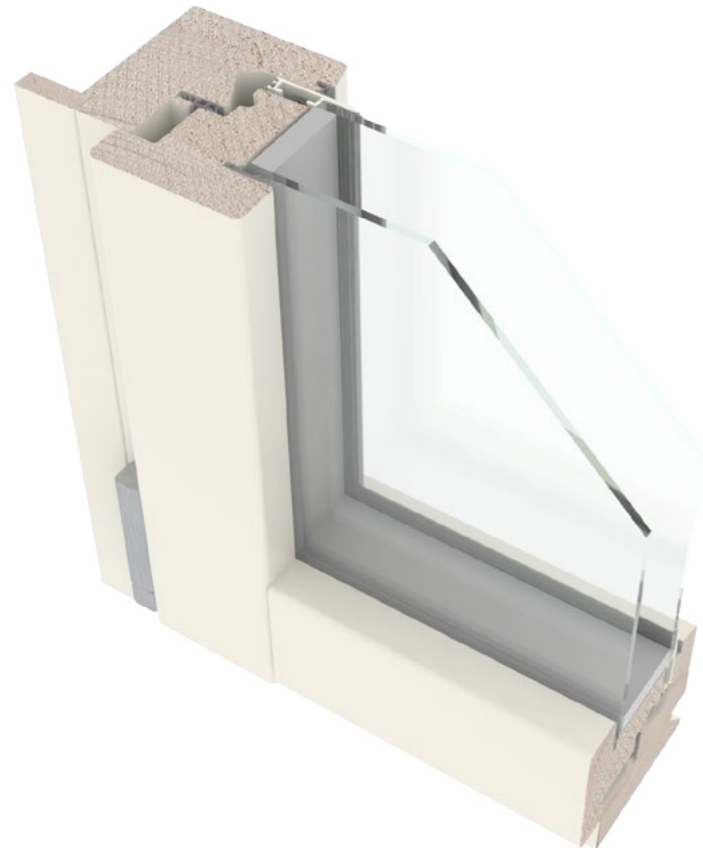

profili:

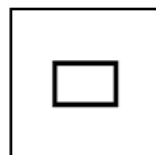

classic



Sistema legno-alluminio moderno che si integra perfettamente con l'involucro edilizio, telaio e anta quasi scompaiono esternamente, la superficie vetrata aumenta e migliora la luminosità degli ambienti interni.

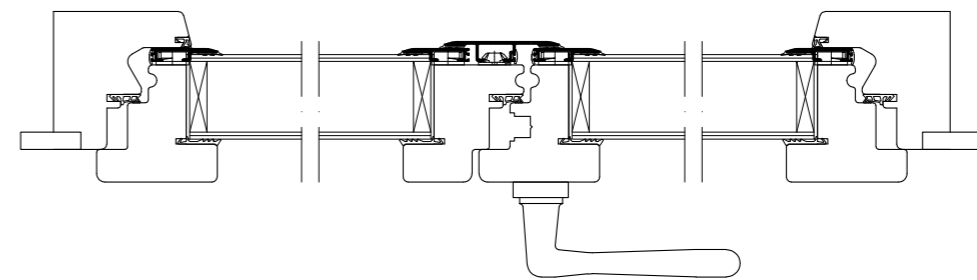

# Sistema-LUCE

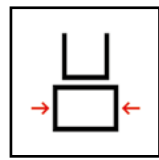

telaio:  
68 x 60 mm

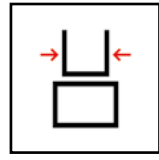

anta:  
68 x 60 mm

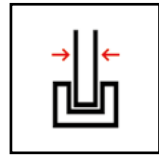

vetrocamera:  
fino a 45 mm

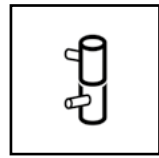

cerniere:  
AGB tipo invisibili

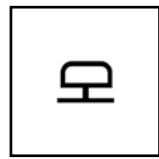

guarnizioni:  
doppia



profili:

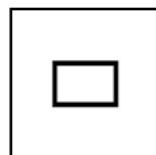

classic



Finestra moderna pensata per coloro che amano lo stile pulito e minimale. L'utilizzo di cerniere a scomparsa rende l'anta a filo del telaio, mentre il profilo da 60 mm aumenta la superficie vetrata rendendo gli ambienti più luminosi.

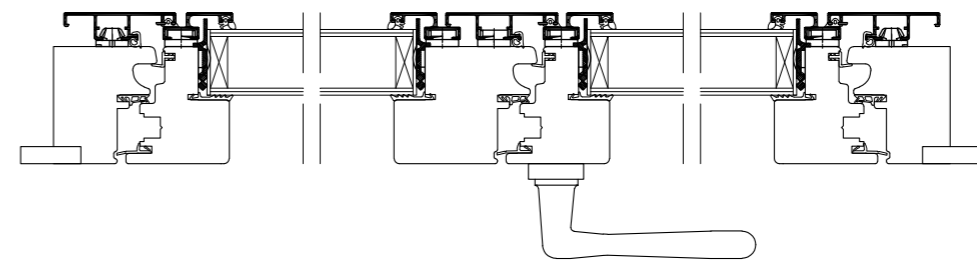

GHOST L-A

## TIPOLOGIA DI APERTURA:

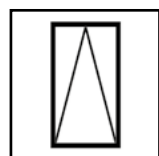

vasistas

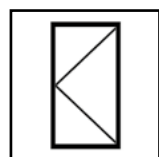

bandiera

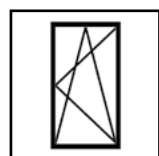

ribalta

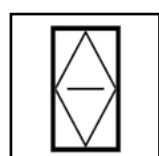

bilico orizzontale

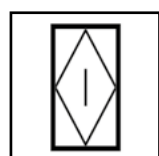

bilico verticale

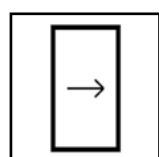

alzante scorrevole

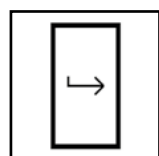

scorrevole complanare

### OPTIONAL

- LAVORAZIONE FINESTRE AD ARCO E TRAPEZIO
- INSERIMENTO TRAFILE IN LEGNO SU ANTE
- SCURI INTERNI CON SPECCHIATURE IN LEGNO MASSELLO O COMPENSATO
- GOCCIOLATOIO IN ALLUMINIO RIVESTITO IN LEGNO O GOCCIOLATOIO INTERAMENTE IN LEGNO

### LEGNI UTILIZZATI:

massello: pino, okumè.

lamellare: pino lamellare lista intera, pino finger joint, okumè, larice, frassino, abete, iroko, rovere, castagno.

La misura delle sezioni del telaio e delle ante è nominale, l'azienda si riserva di apportare modifiche migliorative in ogni momento senza nessun tipo di obbligo verso l'utente finale. Finiture e colori sono soggette a leggere variazioni, sinonimo di artigianalità e lavorazioni su misura, le stesse non possono essere oggetto di contestazione.

# OSCURANTI

54 e 44  
centro storico  
fiorentina  
sportellone

# OSCURANTI

54 E 44



Persiana realizzata con telaio della sezione di mm 54x80 e 44x80 con stecche fisse inclinate da mm 44x12 arrotondate e distanziate.

FIORENTINA



Persiana realizzata con telaio della sezione di mm 54x80 e da stecche fisse di mm 85x11 arrotondate e riquadrate con cornice da 20x11 mm.

CENTRO STORICO



Persiana realizzata con telaio della sezione di mm 54x72, con stecche fisse inclinate da mm 55x11.

SPORTELLONE



Sportellone realizzato con montanti della sezione di mm 54x80, traversi di mm 34x80 e da perline verticali esterne di mm 20x70 avvitate sui traversi.



Ferramenta: squadre e spagnolette in acciaio verniciato colore nero.

Trattamento: impregnante ad immersione, una mano di fondo intermedio e finitura all'acqua per esterni.

PORTE DA INTERNI  
in laminato  
laccate  
massello

Tecnolegno propone diverse soluzioni di porte interne che soddisfano ogni esigenza qualitativa, estetica e funzionale. Si va dai modelli più moderni in laminato a quelli più classici come le porte laccate e pantografate, fino ad arrivare alla porta in massello.



EASY



SMART



CITY



bianco

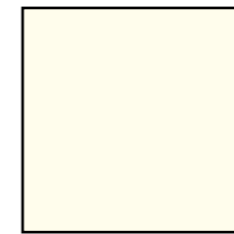

crema



ciliegio



noce nazionale

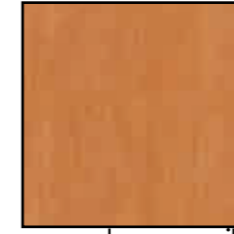

noce tanganyika



noce canaletto



lares



larice bianco

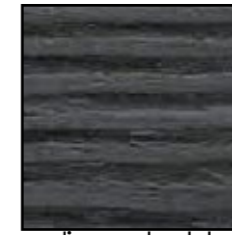

palissandro blu



palissandro bianco



frassino bianco

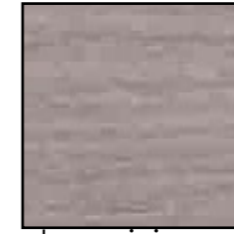

olmo grigio



wengè



rovere sbiancato

Porte interne in laminato realizzate con pannello tamburato, da 4+4 mm, con struttura interna alveolare e intelaiatura perimetrale in abete massello. Telaio in abete massello rivestito in mdf e laminato. Coprifili in mdf rivestiti in laminato.

tutto vetro



vetro e traversi

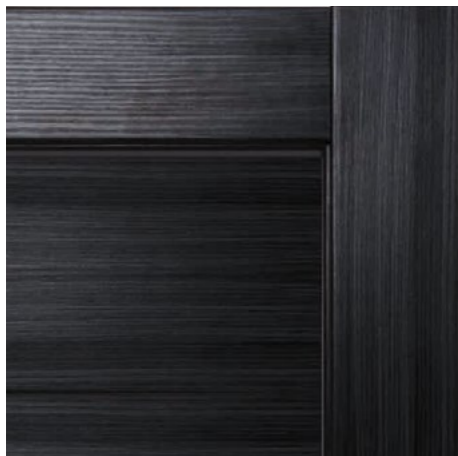

PLUS      GEMINUS      QUADRA      INCISA      PURA

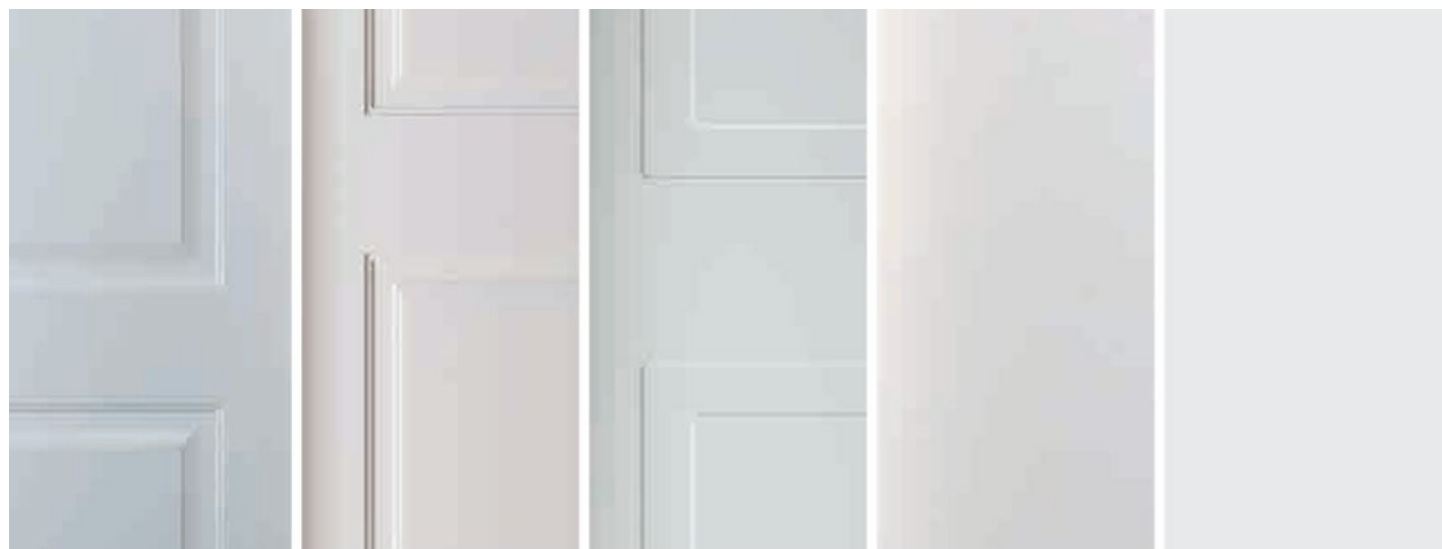

Porte interne laccate realizzate con pannello tamburato, da 8+8 mm, con struttura interna alveolare e intelaiatura perimetrale in abete massello. Telaio in abete massello rivestito in mdf e laccato. Coprifili in mdf laccato.

COLLEZIONI PLUS - GEMINUS - QUADRA

N1A	N1A+F	N1A+FV		
N2B	N2B+F	N2B+FV1	N2B+FV2	
N2C	N2C+F	N2C+V	N2C+FV	
N3A	N3A+F	N3B	N3B+F	N4A
N3E+F	N3C+F	N3D+F	N1A+F	Z5B
COLLEZIONE INCISA				
Z1A	Z2A	Z3A	Z4A	Z2B

COLORE A CAMPIONE



PLUS



GEMINUS



QUADRA



INCISA



AMERICA



LONDON



OLD CITY



ARIZONA



ROMA



PICCADILLY



Modello AMERICA  
Essenza ROVERE  
Finitura BASE

Modello LONDON  
Essenza TOULPIER  
Finitura INVECCHIATO EXTRA

Modello OLD CITY  
Essenza TOULPIER  
Finitura INVECCHIATO EXTRA

Modello ARIZONA  
Essenza ROVERE  
Finitura NATURALE

Modello ROMA  
Essenza NOCINO  
Finitura SCURO

Modello PICCADILLY  
Essenza TOULPIER  
Finitura BASE SENZA SFUMATURA

Infissi

Tecnolegno

## Come raggiungerci

Dall'autostrada del Sole Roma-Milano, uscita Valdichiana e direzione Assisi - Perugia, uscita Bastia Umbra Fiere, seguire direzione Bettona

Percorrendo la superstrada Ravenna-Orte (E 45), uscita Torgiano o Deruta

Dalla statale Flaminia Roma-Ancona, uscita Foligno, seguire per Perugia, uscita Santa Maria Sud, seguire direzione Bettona.

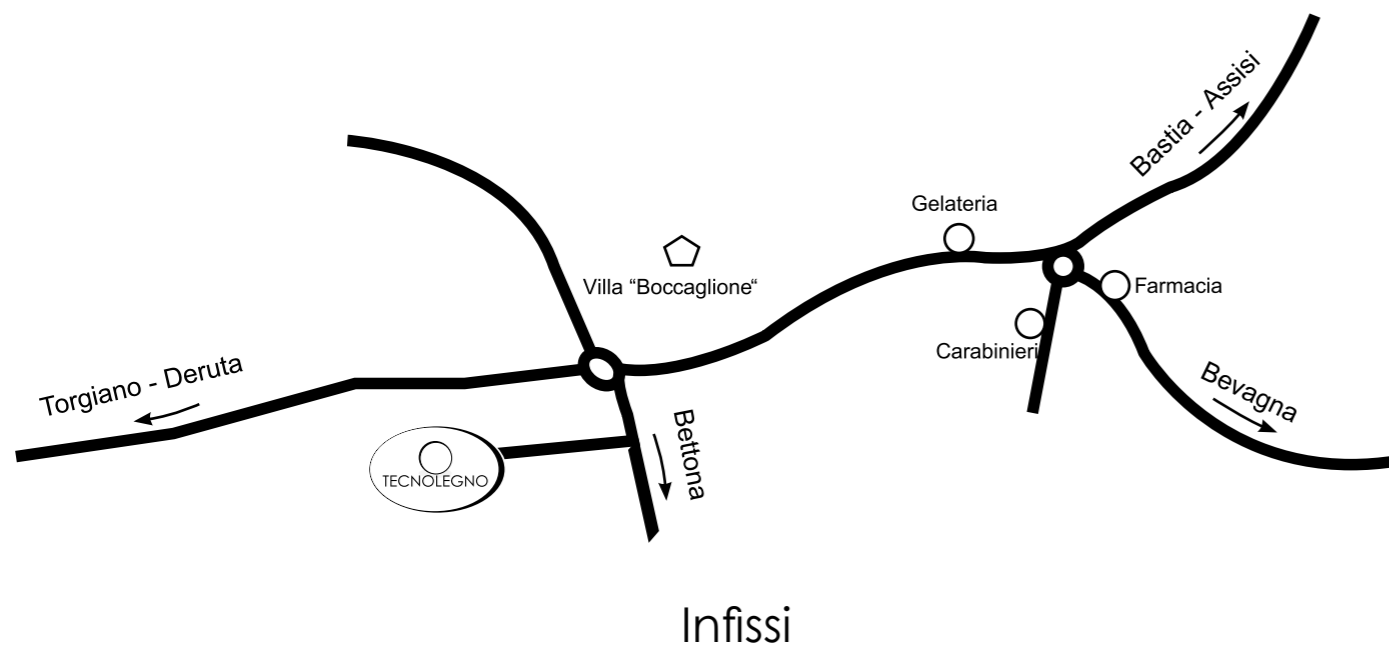

Tecnolegno è:

**installatore**  
**Qualificato**  
LEGNO · ALLUMINIO · PVC



**ALBO LEGNOLEGNO**

cod. 3659

Tecnolegno

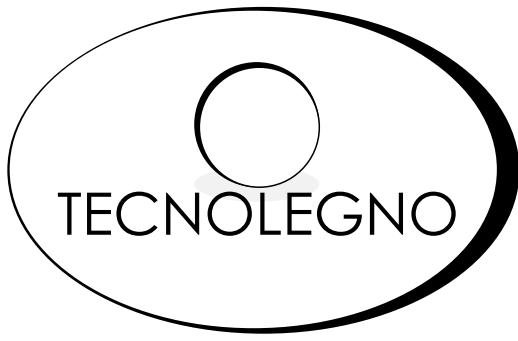

tecnolegno srl

 Via dell'Artigianato, 15  
06084 - Bettona (Pg)

 [www.tecnolegnosrl.net](http://www.tecnolegnosrl.net)

 075 987076

 [tecnolegno@tecnolegnosrl.net](mailto:tecnolegno@tecnolegnosrl.net)

  [tecnolegnosrl](#)